

NOTE 7

34 (SEE NOTE 1)

STANDARD "JBZ" NON-WELDED FIELD JOINT (ONE-PIECE CONSTRUCTION IS OPTIONAL)

A

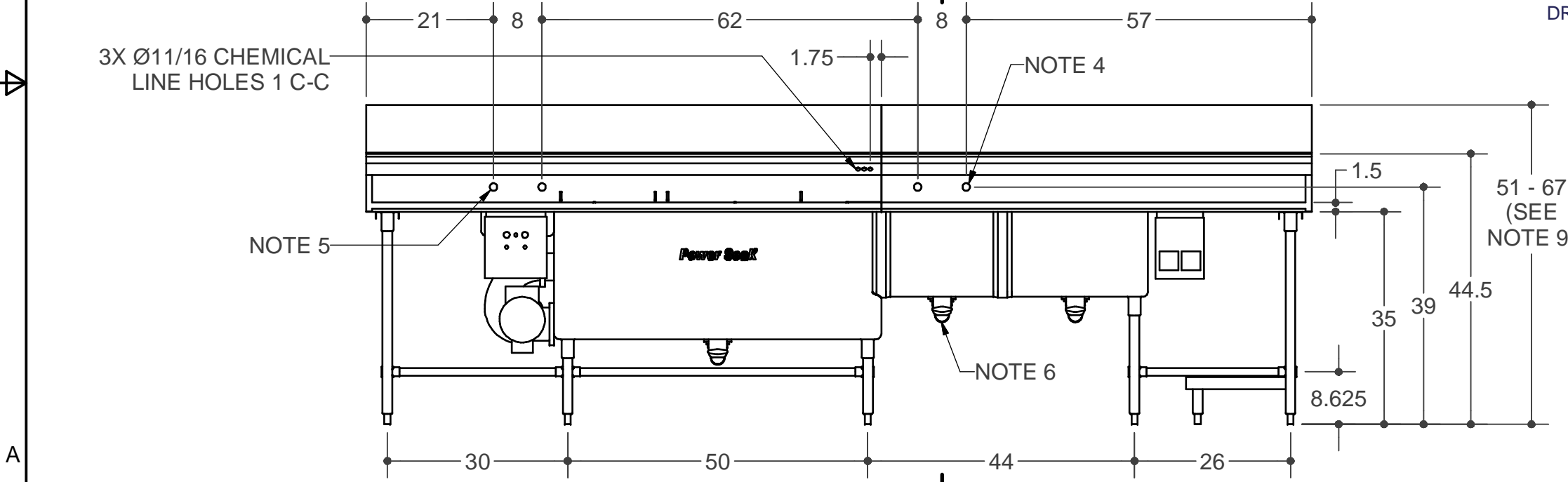

3X Ø11/16 CHEMICAL LINE HOLES 1 C-C

NOTE 5

Power Soak

NOTE 6

A

NOTES:

1. OPTIONAL WIDTHS ARE 30", AND 37".
2. 30" WIDTHS HAVE 24.75" SINKS, 34" WIDTHS HAVE 28.75" SINKS, 37" WIDTHS HAVE 31.75" SINKS.
3. OPTIONAL RINSE AND SANITIZE SINK DEPTHS ARE 18", AND 21".
4. ONE 3/4" IPS PRE-RINSE W/ ADD-A-FAUCET SUPPLIED BY POWER SOAK TO BE FED FROM 1/2" OR 3/4" HOT AND COLD SUPPLY LINES.
5. ONE 1/2" IPS PRE-RINSE SUPPLIED BY POWER SOAK TO BE FED FROM 1/2" OR 3/4" HOT AND COLD SUPPLY LINES.
6. THREE 1-1/2" IPS, REAR EXIT ROTARY BALL VALVE DRAIN SUPPLIED BY POWER SOAK.
7. ONE 1-1/2" IPS OPEN DRAIN SUPPLIED BY POWER SOAK.
8. UNIT IS SHIPPED IN TWO PIECES. (ONE PIECE CONSTRUCTION IS OPTIONAL)
9. AVAILABLE BACKSPASH EXTENSION HEIGHTS ARE 6.5" AND 22.5".
10. SEE SHEET 2 FOR SHEET PAN OR MEAT TRAY RACKING AND DRYING SYSTEM INFORMATION.

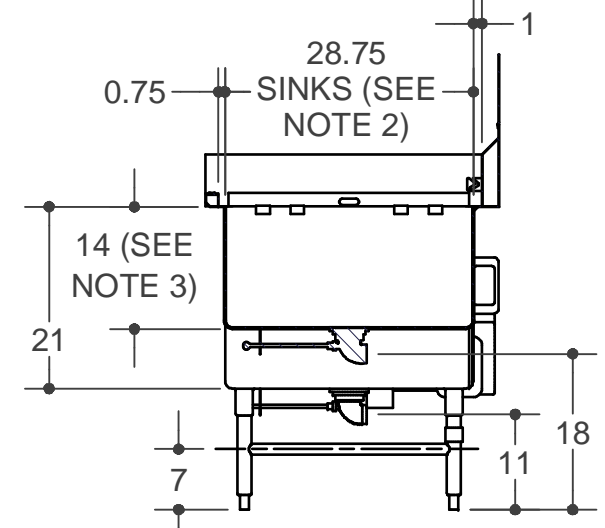

SECTION A-A

MODEL 200PSS156L

<small>POWER SOAK SYSTEMS INC. AND ITS SUBSIDIARIES CLAIM PROPRIETARY RIGHTS IN THE MATERIAL HEREIN DISCLOSED. IT IS SUPPLIED IN CONFIDENCE. WITHOUT PREJUDICE TO ANY PATENT RIGHTS OF POWER SOAK SYSTEMS INC. AND MAY NOT BE REPRODUCED, SHARED OR USED WITHOUT POWER SOAK SYSTEMS INC. AND ITS SUBSIDIARIES, WRITTEN PERMISSION. ALL INFORMATION ALWAYS REMAINS THE SOLE PROPERTY OF POWER SOAK SYSTEMS INC.</small>		Power Soak Systems 903 E. 104 Street, Kansas City, MO 64131 PH 816-222-2400 FAX 816-222-2419	
		DESCRIPTION: Standard PS-200 Left V11 PSS	
Drawn by: Josh Huisenga 6/13/2007	SIZE B	DWG NO.	REV
Checked by:	SCALE: NTS	©2007 POWER SOAK SYSTEMS INC.	SHEET 1 OF 2

ELECTRICAL CONNECTION

PS-200 SOLID STATE CONTROL/7000 WATT HEATER
WASH TANK SIZES 30", 36", 42", 48", 2 HP

- 208/60/1, 45.1 AMPS (50 AMP SERVICE REQD)
- 208/60/3, 26.7 AMPS (30 AMP SERVICE REQD)
- 230/60/1, 39.8 AMPS (50 AMP SERVICE REQD)
- 230/60/3, 24.0 AMPS (30 AMP SERVICE REQD)
- 480/60/3, 11.6 AMPS (15 AMP SERVICE REQD)

PS-200 SOLID STATE CONTROL/7000 WATT HEATER
WASH TANK SIZES 54", 60", 66", 72", 3 HP

- 208/60/3, 29.9 AMPS (40 AMP SERVICE REQD)
- 230/60/3, 26.8 AMPS (30 AMP SERVICE REQD)
- 480/60/3, 11.6 AMPS (15 AMP SERVICE REQD)

INTERNATIONAL (50 HERTZ):

PS-200 SOLID STATE CONTROL/6405 WATT HEATER
WASH TANK SIZES 30", 36", 42", 48", 2 HP

- 220/50/1, 38.6 AMPS (50 AMP SERVICE REQD)

PS-200 SOLID STATE CONTROL/7000 WATT HEATER
WASH TANK SIZES 30", 36", 42", 48", 2 HP

- 380/50/3, 15.4 AMPS (30 AMP SERVICE REQD PLUS NEUTRAL AND GROUND CONNECTIONS)

PS-200 SOLID STATE CONTROL/7000 WATT HEATER
WASH TANK SIZES 54", 60", 66", 72", 3 HP

- 380/50/3, 23.3 AMPS (30 AMP SERVICE REQD PLUS NEUTRAL AND GROUND CONNECTIONS)

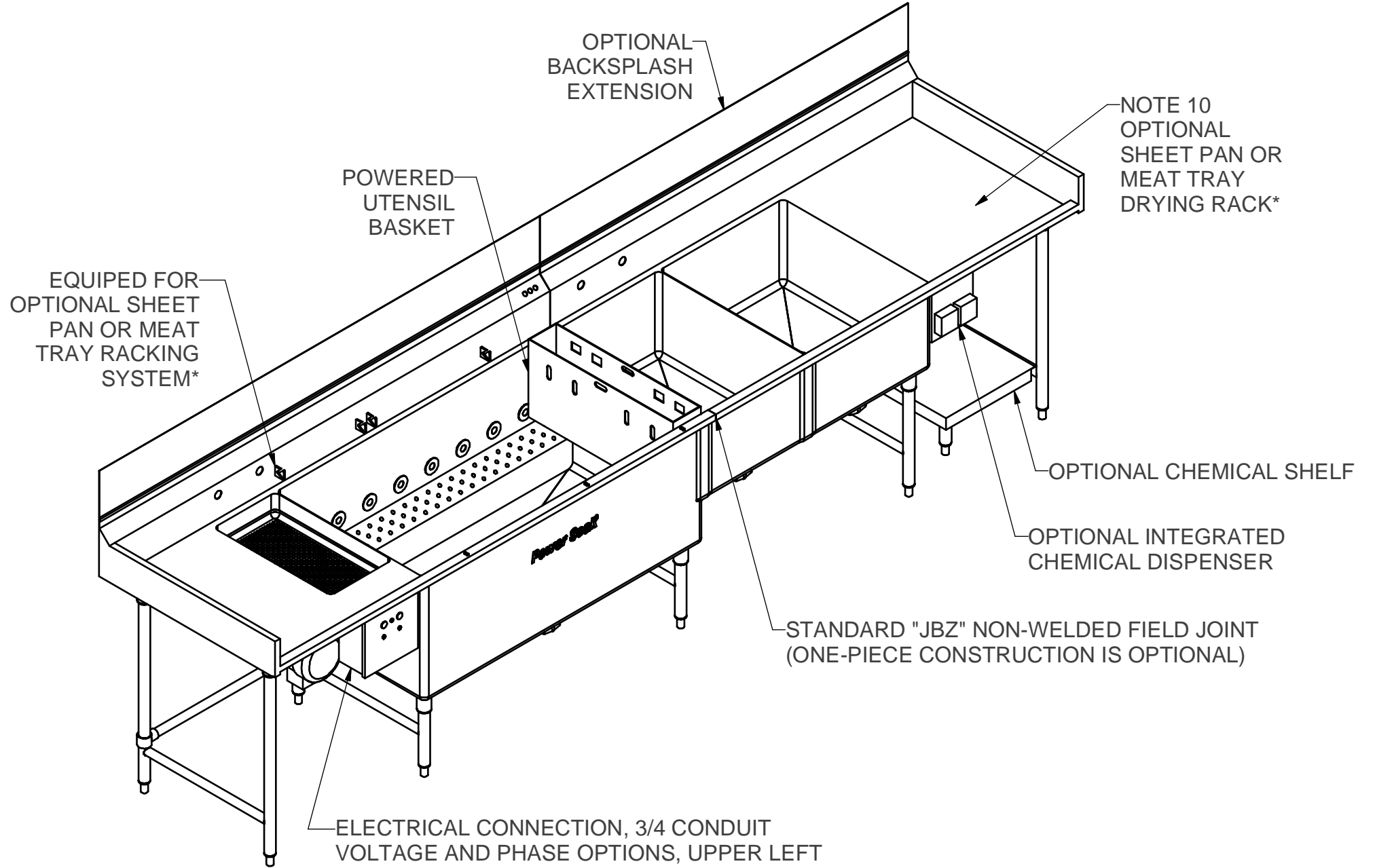

*CONTACT FACTORY FOR DETAILS ON SHEET PAN AND MEAT TRAY COMPATABILITY.

MODEL 200PSS156L

<small>POWER SOAK SYSTEMS INC. AND ITS SUBSIDIARIES CLAIM PROPRIETARY RIGHTS IN THE MATERIAL HEREIN DISCLOSED. IT IS SUPPLIED IN CONFIDENCE. WITHOUT PREJUDICE TO ANY PATENT RIGHTS OF POWER SOAK SYSTEMS INC. AND MAY NOT BE REPRODUCED, SHARED OR USED WITHOUT POWER SOAK SYSTEMS INC. AND ITS SUBSIDIARIES, WRITTEN PERMISSION. ALL INFORMATION ALWAYS REMAINS THE SOLE PROPERTY OF POWER SOAK SYSTEMS INC.</small>		Power Soak Systems 903 E. 104 Street, Kansas City, MO 64131 PH 816-222-2400 FAX 816-222-2419	
		DESCRIPTION: Standard PS-200 Left V11 PSS	
Drawn by: Josh Huisenga 6/13/2007	SIZE B	DWG NO.	REV
Checked by:	SCALE: NTS	©2007 POWER SOAK SYSTEMS INC.	SHEET 2 OF 2